

**2023-2024**

**Illinois TSA**

**Competitive Events  
Guide**

## CONTENTS

EVENT	PAGE
GENERAL RULES	3 -5
Architectural Model – Completed at school and brought to competition	6-8
Chapter Team (Written) – Live at competition	9
Creed – Live at competition	10-11
Computer-Aided Design Engineering – Live at competition	12-13
Debating Technological Issues – Live at competition	14-17
Dragster Design – Completed at school and brought to competition	18-22
Engineering Design – Live at competition	23-25
Imaging Technology – Completed at school and brought to competition	26-27
Marine Challenge – Completed at school and brought to competition	28-29
Prepared Presentation – Live at competition	30-32
Promotional Graphics – Completed at school and brought to competition	33-34
Safety in Technology – Completed at school and brought to competition	35-36
Structural Engineering – Truss – Completed at school and brought to competition	37-39
Structural Engineering – Bridge – Completed at school and brought to competition	40-43
Technical Design – Live at competition	44-46
Technology Bowl – Oral – Live at competition	47-49
Technology Bowl – Written – Live at competition	50-51
Technology Problem Solving – Live at competition	52-54
TSA Achievement Program	55-62
TSA Honor Society	63-66
<b>Over Under VEX Robotics Competition – See</b> <a href="https://www.vexrobotics.com/v5/competition/vrc-current-game">https://www.vexrobotics.com/v5/competition/vrc-current-game</a>	

## GENERAL RULES

### I. COMPETITIVE EVENTS

The officially approved **Level 1 AND Level 2** competitive events for IL-TSA are:

Architectural Model  
Chapter Team Written  
Creed  
Computer-Aided Design Engineering  
Debating Technological Issues  
Dragster Design  
Engineering Design  
Imaging Technology  
Marine Challenge  
Prepared Presentation  
Promotional Graphics  
Safety in Technology Challenge  
Structural Engineering – Bridge  
Structural Engineering – Truss  
Technical Design  
Technology Bowl Oral  
Technology Bowl Written  
Technology Problem Solving Competitions  
VEX Robotics Competition

### II. LEVELS OF COMPETITION

The IL-TSA competitive events are divided into two (2) levels of competition, Level I for students in Middle Schools including grades 6-9, and Level II for students in grades 10-12. These levels allow for participation of members in competition with students more nearly their own age and skill level. In Senior High schools with members in grades 9-12, ninth graders will compete in Level I.

### III. PARTICIPATION

- In chapter and team events, a TSA chapter must enter the event according to the level which corresponds to its official school classification.
- Students and advisors must be registered for the State Conference to compete in any of the competitive events, regardless of competitive events that are completed at the local school and brought to the State Conference.
- TSA members, advisors, and chapters, must be in good standing with TSA to enter any competitive event.
- TSA membership rights extend through the entire year of graduation. It is permissible for students who graduate at mid-term to compete at the State Conference which immediately follows their graduation.

### IV. ENTRY RESTRICTIONS

**See current year's State Events for specific participant rules.**

(Note: Events for which no levels are listed have only one level of competition)

### V. AWARDS

Awards will be presented to the winning entries in each competitive event at the Awards Presentation Ceremony. In most cases, first through third place awards will be presented.

### VI. COMPETITIVE EVENTS ATTIRE

During most events, students must wear official or professional attire as described in the files found on the IL-TSA web site ([https://www.iltsa.org/images/ILTSA\\_Files/Dress\\_Guidelines.pdf](https://www.iltsa.org/images/ILTSA_Files/Dress_Guidelines.pdf)). It is the responsibility of each advisor and contestant to be informed concerning acceptable dress for each event. Failure to dress appropriately may result in contestants not being allowed to compete.

## VII. ADDITIONAL CONCERNS

- In the event a question or problem arises that has not been covered in the "General Rules" or the individual competitive event guidelines, the Competitive Events Committee will render a decision for the conference.
- Should a conflict develop which prevents a member from participating in all of his/her selected events, the contestant will decide which event will be eliminated.
- It is the individual responsibility of all contestants to obtain rules and guidelines for all events which they would like to enter. Lack of knowledge or understanding about a particular event will not be a reason or excuse for individual changes or adjustment considerations.
- Contest concerns during the State Conference, for any event, should be submitted in writing to the Competitive Events Coordinator, Mr. Bryan Erickson to be considered by the Competitive Events Committee.

## ARCHITECTURAL MODEL

OVERVIEW: TSA members entering the Architectural Model Event are required to submit a floor plan and a three-dimensional model of the specified structure according to the directions for that year. **This event is completed at the home school and brought to the State Conference for judging/ testing.**

### I. CONTEST PURPOSE

The purpose of the Architectural Model Contest is to provide a means for TSA members to demonstrate their ability to design, draw, and construct an architectural model to scale.

### II. ELIGIBILITY FOR ENTRY

- All IL-TSA members in good standing are eligible to enter the Architectural Model Contest.
- There is no limit to the number of entries that a chapter may enter.
- A member may enter only one model in the Architectural Model Competition.

### III. LEVELS OF COMPETITION

There are two (2) levels of competition in the Architectural Model Contest, Level I (grades 6-9) and Level II (grades 10-12), as described in the General Rules.

### IV. TIME LIMITATIONS

The Architectural Model Contest is not a "timed" event. The only time requirement is that the model must be constructed during the present school year.

### V. SPECIFIC REGULATIONS

- The Architectural Model entry cannot be placed on a site board larger than 24" x 24".
- The floor plan drawing(s) should be drawn or printed to a scale of  $\frac{1}{4}'' = 1'-0''$  and the model may be built at any appropriate scale that allows it to fit on the 24" x 24" board.
- The roof of the model must be removable to allow inspection of the inside details.
- Materials that may be used in constructing the architectural model include, but are not restricted to the following:
  - Balsa wood
  - Plywood - not to exceed  $\frac{1}{4}''$  in thickness
  - Hardboard or paneling - not to exceed  $\frac{1}{4}''$  in thickness
  - Styrofoam/urethane (firm textured)
  - Dowels - not to exceed  $\frac{1}{4}''$  diameter

- Illustration board
- Glass or liquid may not be used.
- A complete list of materials shall accompany each entry.
- Floor and wall coverings such as rugs, linoleum, wallpaper, etc. may be used in construction.
- No furniture is to be included.
- Commercial kits are not permissible.
- The floor plan(s) designed and drawn by the member submitting the entry must accompany each Architectural Model. Only the floor plan shall be submitted. Other drawings are not allowed. The maximum size for drawings shall be 24" X 24".
- Specific guidelines and model specifications shall be set by the IL-TSA Competitive Events Committee in consultation with the Board of Directors for each year or years as deemed necessary by the board. These specific guidelines shall be made available to each IL-TSA chapter annually. Specific guidelines shall be set for Level I and Level II entries.

#### **VI. PROCEDURE**

- Contest participants must register for the event in accordance with procedures established for each conference.
- Contestants must have the Architectural Model in the judging area before the time deadline specified in the conference program.
- Architectural Model entries may be picked up at the designated time.

#### **VII. REQUIRED CONTEST PERSONNEL AND EQUIPMENT**

- Contest coordinator
- A team of judges - ideally three but fewer are acceptable
- Display tables for Architectural Model entries
- Judge's rating sheets

## VIII. CRITERIA FOR JUDGING

- Architectural Model entries shall be evaluated using the following criteria.

Quality of drawing	15 points
Overall Appearance	10 points
Quality of Construction	15 points
Creativity and Innovation	10 points
Meets Design Problem Criteria	15 points
Interior Planning	20 points
Interior planning includes traffic flow, placement of rooms, and planning within each room.	
Exterior Planning	10 points
Exterior planning includes landscaping (if applicable), how well the exterior compliments the environment, and how well the exterior compliments the structure.	
Materials List	5 points
TOTAL 100 points	

- Awards first, second, and third place awards will be presented in each level of competition.

### Architectural Model

#### **Level I: 1 ½ Story House**

1200-1500 square feet of living space (does not include a garage in square feet)

Minimum Requirements Include:

Kitchen, Dining Area, Living Room, 2 Bedrooms, 2 Full Bathrooms, 1 Laundry Area, and 1 Car Garage, which is not figured into the square foot requirement

\*Other areas may be included in your plan but are not required.

#### **Level II: Duplex**

Each unit of the duplex should be between 1200-1500 square feet (not including the garage).

Minimum Requirements include:

Kitchen, Living Room, 2 Bedrooms, 1 1/2 Bathrooms, Laundry Room, and 1 Car Garage, which is not figured into the square foot requirement.

Assume the duplex is constructed on a crawl space.

\* Other features may be included but are not required.



## **CHAPTER TEAM - Written**

OVERVIEW: Participants complete a written examination that includes parliamentary procedures and relative TSA meeting procedures.

### **I. CONTEST PURPOSE**

The purpose of the Chapter Team Competition is to allow TSA members to demonstrate their ability to lead and follow accepted rules for conducting a business meeting.

### **II. ELIGIBILITY FOR ENTRY**

- All IL-TSA chapters in good standing are eligible to enter the Chapter Team contest.
- Unlimited individual entries from each chapter are allowed for this competitive event.

### **III. LEVELS OF COMPETITION**

There is one (1) level of competition in the Chapter Team Contest.

### **IV. TIME LIMITATIONS**

Contest period.

### **V. SPECIFIC REGULATIONS**

- Written materials such as the TSA handbook, minutes, etc., may not be taken into this contest by any member of the team.

### **VI. PROCEDURES**

- Contest Participants must register and follow the guidelines for the event in accordance with the procedures established for each conference.

### **VII. REQUIRED CONTEST PERSONNEL AND EQUIPMENT**

- Contest coordinator
- A copy of the contest guidelines
- Answer key to written examination

### **VIII. CRITERIA FOR JUDGING**

Chapter Team contestants shall be rated using the following criteria:

Total number of questions answered correctly.

## **CREED**

OVERVIEW: Contestants in the Creed Contest are required to recite the TSA Creed from Memory.

### **I. CONTEST PURPOSE**

The purpose of the Creed Contest is to provide a means for TSA members to demonstrate their ability to memorize and recite the Creed.

### **II. ELIGIBILITY FOR ENTRY**

- Entries are limited to three (3) per chapter.

### **III. LEVELS OF COMPETITION**

Level 1 competition only.

### **IV. TIME LIMITATIONS**

This is not a "timed" event. Each contestant will be given ample time for his/her presentation.

### **V. SPECIFIC REGULATIONS**

- All contestants should report to the designated area on time. Contestants who fail to report on time will be disqualified.
- The Contest Coordinator will introduce each contestant by registration number.
- No written material or notes may be used.

### **VI. PROCEDURES**

- Contest participants must register for this event in accordance with procedures established for each conference.
- Contest participants should assemble in the general area of the contest prior to the time designated for the contest.
- The contestant should begin by saying, "The Technology Student Association Creed..."
- An audience is permitted for this contest.

## VII. REQUIRED CONTEST PERSONNEL AND EQUIPMENT

- Contest coordinator
- Teams of judges - ideally three but fewer are acceptable - one of the judges should act as monitor to check the text for accuracy.
- A copy of the contest guidelines
- Judge's rating sheets
- Pens and pencils
- A copy of the TSA Creed for each judge
- A list of contestants in order of appearance
- A contest room with:
  - A podium
  - One table and three chairs for judges
  - Fifteen to twenty chairs for the audience
- A waiting area close to the contest room with:
  - A host to watch the door and regulate entrance into the contest room.
  - Chairs for contestants waiting for their turn to compete

## VIII. CRITERIA FOR JUDGING

- The six paragraphs of the Creed shall count for a maximum of 168 points, one (1) point per word.
- Failure to say a word, saying a word incorrectly, or substituting words will result in penalties of one (1) point per word missed.
- Contestants saying a paragraph out of order will be notified at the end of the paragraph so that if they realize the mistake, they can go back and correct it with the loss of only ten (10) points.
- Each judge will complete, without consultation, a rating sheet for each entry. Points will be assigned according to the following:

Words of the Creed text	168 points
Clarity and Enunciation	7 points
Projection and Force	10 points
Poise (confidence, body control, and posture)	5 points
Personal appearance, grooming, and appropriate attire	10 points

## COMPUTER-AIDED DESIGN ENGINEERING

OVERVIEW: TSA contestants demonstrate their technical knowledge of drafting by completing a written test and solving an engineering graphics problem using standard drafting techniques.

### I. CONTEST PURPOSE

Use complex computer graphics skills, tools, and processes to develop two and/or three-dimensional representations.

### II. ELIGIBILITY FOR ENTRY

All IL-TSA chapters in good standing are eligible to enter the Computer-Aided Design Engineering contest.

Entries are limited to two individuals per chapter, per level.

### III. TIME LIMITS

Two hours to complete the written and performance part of the contest.

### IV. REGULATIONS

- Contestants entering this competition are required to bring their own computer, monitor, etc., as well as software. No equipment will be available at the TSA competition site.
- Participants must work independently.
- Each participant will print their solution within five minutes of the conclusion of the contest.
- Participants are not allowed to leave the contest area once the contest has started.
- Participants identify their work using only their conference identification number.

### V. REQUIRED CONTEST PERSONNEL AND EQUIPMENT

- Contest coordinator
- A team of judges - ideally three, but fewer are acceptable
- A copy of the contest guidelines
- Written tests, pencils, and answer sheets
- Drawing paper, copies of problems, and correct solutions
- Judge's rating sheets
- Pens for judges
- Tables, chairs, and computers for contestants

**VI. EVALUATION**

Accuracy of solution	35 points
Placement of views	10 points
Accuracy of Drawing	20 points
Dimensioning	10 points
Correct Lettering	10 points
Correct Line quality	15 points
Written test score	100 points
TOTAL	200 points

**Awards**

First, Second, and Third place awards will be presented.

## DEBATING TECHNOLOGICAL ISSUES

OVERVIEW: Team members work together to prepare for a debate against a team from another chapter. The teams will be instructed to take either the Pro or Con side of the selected subtopic.

The theme and topic are given annually by National TSA:

Theme: Technology and Infrastructure

- Subtopic 1: Autonomous vehicles are the answer to increasing traffic demands, especially in large urban areas.
- Subtopic 2: Current carbon and renewable energy policies have a negative impact on power grid reliability and consumer pricing.
- Subtopic 3: Manufacturing companies should be exempt from restrictions on waste production due to their contributions to society.

### PURPOSE

The skill of debating is essential for government, business, and technology leaders as our society faces new challenges in areas such as medicine, space exploration, pollution, global warming, economics, manufacturing, and agriculture. Tied to these challenges is the necessity for proficiency in science, technology, engineering, and mathematics. Developing debate and communication skills in students, in conjunction with a focus on topics related to STEM, is an effective way to increase technological literacy.

### ELIGIBILITY

There is no level for this competition, meaning that all participants will compete against one another. Entries are limited to three (3) teams of two (2) per chapter.

### TIME LIMITS

- A. Each speaker is allowed a maximum of three (3) minutes.
- B. Each team will be given a two (2)-minute conference break.
- C. All research and preparation must be started and completed during the current school year.

### ATTIRE

Competition attire is required for this event.

### PROCEDURE

- A. Participants research all subtopics as listed in the overview and should be prepared to debate any of the subtopics from both Pro and Con views. All participants will be assigned the same subtopic. A new subtopic may be assigned for the semifinals, and all participants will debate that new subtopic.

- B. All members are allowed to speak during the time given.
- C. Pre-debate meeting: Participants report to the event area at the time and place stated in the conference program to receive an assigned debate time, a subtopic, and general directions and information from the judging team. Failure of participants to attend this meeting will result in disqualification. This meeting will be held for both preliminary heats and the semifinals portion of the event. Students should be reminded in this meeting that they may not state their individual or school name in the presence of judges.
- D. Each team reports to the preparation room fifteen (15) minutes before the scheduled debate time.
- E. One (1) minute before opposing teams are instructed to report to the presentation room, each team will be informed of the view (Pro or Con) it will be presenting.
- F. Once the teams are informed of the view they are to take, they will be escorted to the presentation room.
- G. Order of debate format.
  - 1. Pro speaker, maximum of three (3) minutes
  - 2. Con speaker, maximum of three (3) minutes
  - 3. Conference break, two (2) minutes
  - 4. Pro rebuttal, maximum of three (3) minutes
  - 5. Con rebuttal, maximum of three (3) minutes
- H. The escort will introduce the Pro team by ID number and the team will be instructed to sit to the left side of the podium. The first speaker should sit next to the podium. At this time, participants will present their schedule card and reference summary to the judges.
- I. The Con team will be introduced by ID number and will be instructed to sit to the right side of the podium. The first speaker is to sit next to the podium. At this time, participants will present their schedule card and reference summary.
- J. When the judges and teams are ready, the Pro speaker will be instructed to move to the podium and begin. Timing starts when the speaker begins. After 2 minutes and 45 seconds, the timer will hold up a 4" x 6" card on which is written "15 seconds." Penalty points will be deducted when a speaker exceeds the allotted time.
- K. When the Pro speaker is finished and has been seated, the Con speaker will move to the podium and begin, according to the same procedure noted above.
- L. When the Con speaker is finished and has been seated, the timer will announce a two (2)-minute conference period in which both teams may prepare their rebuttal.

- M. At the conclusion of the two (2)-minute conference period, the timer will announce that the conference period is over and the Pro rebuttal speaker will approach the podium. Timing starts when the speaker begins. After 2 minutes and 45 seconds, the timer will hold up a 4" x 6" card on which is written "15 seconds." Penalty points will be deducted if a speaker exceeds the allotted time.
- N. When the Con rebuttal speaker (as in L. above for the Pro rebuttal speaker) is finished and has been seated, the timer will announce to both teams that they may leave the presentation room.
- O. Participants will give the judges a one (1)-page list of reference materials used to research the debate subtopics. This reference list must be a word-processed document that can be printed on both sides of a sheet of paper. MLA format must be used in citing resources. A copy of the reference summary is to be made and turned in to the judges each time a team competes.
- P. Should there be an odd number of teams entered in this event, one team will debate twice, based on a random drawing. If a team debates twice, that team must again provide to the judges the page that lists reference materials used. The team that debates twice may or may not have to debate both sides of this issue. If the team does debate twice, both debates will be scored and the highest score will be used for placement.
- Q. If a preliminary heat format is being used, twelve (12) semifinalists will be posted in random order.
- R. Semifinalists will report to the event area at the time and place stated in the conference program to receive an assigned debate time, as well as general directions and information from the judging team.
- S. Each team reports to the preparation room at its assigned time.
- T. Procedures D — O will be followed to determine the ten (10) finalists.
- U. Room set-up:
- Pro team Podium Con team
  - Judge Timer Judge

## **REGULATIONS**

- A. Participants must debate the current year's selected subtopic, as assigned at the conference.
- B. Pre-written notes may be used. Notes must be written on 3" x 5" notecards.
- C. Notes may be taken during the debate.
- D. A three (3)-ring binder of reference material, as noted on the reference list provided to the judges, may be used during the debate.
- E. No audio-visual materials of any form may be used.



- F. Participants are not allowed to hear the debates of other teams.
- G. Read the General Rules and Regulations in the front of this guide for information that applies to all of TSA's competitive events.
- H. No observers or assistants are allowed in the preparation room.
- I. No observers are allowed to view the preliminary heats.
- J. Observers are allowed in the debate room during the semifinalist debates. No audio or visual recording devices are allowed. No talking or gesturing is permitted. Observers are not allowed to enter or leave during a presentation. There is no applause until the debate is completed.
- K. Teams are penalized five (5) points for speaking any amount of time over the allotted time. See the official rating form for time deductions.
- L. Each team is required to submit a summary of references (used to prepare for the event) on an 8½" x 11" sheet of paper; both sides of the paper may be used. The event title, the event topic, and a line for the entry number must be printed at the top of the front side of the paper. The reference summary must be word-processed (handwritten is not acceptable). MLA format must be used to cite sources. References for subtopics is to be submitted on one (1) sheet of paper, not a separate sheet for each subtopic. The summary of references must be given to the judges at both preliminary heats and semifinalist rounds. Not having a summary of references will be grounds for a rules violations or disqualification.

## **EVALUATION**

Evaluation will be based upon a team's knowledge of the topic and communication ability (i.e., the use of debate and presentation skills).

## DRAGSTER DESIGN

OVERVIEW: TSA members entering the Dragster Design Contest are required to design, draw, and build a CO<sub>2</sub>-powered model dragster. Design, speed, craftsmanship, and drafting skills are primary considerations in evaluation. **This event is completed at the home school and brought to the State Conference for judging/ testing. [Please review the dragster specifications and tolerances because they are different from National TSA.](#)**

### I. CONTEST PURPOSE

The purpose of the Dragster Design contest is to provide a means for TSA members to demonstrate and develop their ability to design, draw, and construct a product within a rigid set of specifications.

### II. ELIGIBILITY FOR ENTRY

- All IL-TSA members in good standing are eligible to enter the Dragster Design Contest.
- There is no limit to the number of entries that a chapter may enter.
- A member may enter only one model in the Dragster Design Competition.
- A member entering the Dragster Design competition does not need to be in attendance at the State Conference.

### III. LEVELS OF COMPETITION

There are two (2) levels of competition in the Dragster Design Contest, Level I (grades 6-9) and Level II (grades 10-12), as described in the General Rules.

### IV. TIME LIMITATIONS

The dragsters entered in the Dragster Design contest at the state conference must have been constructed during the current school year. Dragsters which were constructed during a previous year are not eligible for entry, even if they had not been entered in competition the previous year.

### V. SPECIFIC REGULATIONS

- All entries must be submitted at the assigned time and place designated for each conference. Contestants are responsible for obtaining information on registration times.
- All entries must be delivered free of needed repair and/or maintenance at the time of check-in.
- CO<sub>2</sub> cartridges will be provided by IL-TSA.
- Each entry must be submitted with a full-size metric drawing of the completed dragster. A two-view (top and side) drawing with metric dimensions shall be made on 11 x 17 drawing paper. A three-view (top, side, and end) drawing is acceptable but will not change the point

allocations. Drawings should be developed using standard engineering procedures and practices. Drawings may be made using ink or pencil with traditional drafting methods or CAD. Originals, blueprints, or copies will be accepted. The title block will only include "Entry Number \_\_\_\_\_," which will be assigned at registration time and placed on the entry prior to being turned in.

- The official distance between the start line and the finish line on the race track is twenty (20) meters (65'-7½"). If for any reason a distance other than twenty meters is used, that distance will remain constant for all entries in the event.
- Following a strict set of specifications is an integral part of this event. Dragsters that do not meet the following specifications and tolerances are disqualified from competition.

## DRAGSTER SPECIFICATIONS AND TOLERANCES

### DRAGSTER BODY

Body Blank - The body of the dragster shall be one-piece. No parts such as body strengtheners, fenders, plastic canopy, exhausts, or air foils may be attached to or enclosed within the dragster. Fiberglass or shrink wrap are considered body strengtheners and cannot be used on car body or wheels for any reason. Bearings and lubricants may be used in construction. Two or more like or unlike pieces glued together will not be considered one-piece construction.

### MINIMUM MAXIMUM

Body length	275mm ..... 285mm
Body height at rear with wheels	no minimum.....75mm
Body mass with wheels	40g .....no maximum (without CO2 cartridge)
Body width at axles, front & rear	35mm ..... 42mm
Body total width including wheels	no minimum.....90mm

### AXLES, AXLE HOLES, WHEELBASE

Dragsters must have two (2) axles per car, no more. Plastic axles may be used in competition. However, design elements regarding impact should be considered when engineering the dragster.

Bottom of axle hole above bottom of car	5mm .....10mm
Rear axle hole from rear of car	9mm ..... 100mm
Wheelbase - distance between axle centers	105mm .....270 mm

Bearings, bushings, and lubricants may be used.

Glue may be used to secure bearings to body.

## POWER PLANT (CO2 cartridge) HOLE

The power plant hole is located at the farthest point at the rear of the car and must be drilled parallel to the bottom of the body blank to assure proper puncture of the CO2 cartridge. A minimum of 3 mm thickness around the entire power plant hole must be maintained on the dragster for safety.

Power plant hole depth	45mm .....55mm
Power plant safety zone thickness	3mm
Power plant chamber diameter	19mm .....20mm
Lowest point of chamber diameter to race surface	26mm .....40mm

\*Measured to center of hole from body bottom

## EYE SCREWS

Dragsters must have two (2) eye screws per car that meet tolerances, no more. They must not make contact with the racing surface. The track string must pass through both screw both screw eyelets, which are located on the center line of the bottom of the car. Glue may be used to reinforce the eye screws in the body bottom. It is the responsibility of the car designer to see that the eye screw holes are tightly closed to prevent the track line from slipping out. As with all adjustments, this must be done prior to event check-in.

Eye screw inside diameter	3 mm ..... 5mm
Eye screw spacing, distance apart	150mm ..... 270mm

## WHEELS

Dragsters must have four (4) wheels, no more. Front wheels must meet front wheel specifications and rear wheels must meet rear wheel specifications as listed below. All four wheels must touch the racing surface at the same time. All wheels must roll. The wheels must remain independent of each other. They may not be glued together. Wheels must be made entirely from plastic. Dimensions must be consistent for the full circumference of the wheel.

Front wheel diameter	30mm .....37mm
Front wheel width at surface contact point	1.5mm .....5mm
Rear wheel diameter	30mm ..... 40mm
Rear wheel width at surface contact point	12mm .....18 mm

## SPACER WASHERS, CLIPS

Spacer washers	8
Axle clips	8

Silicone or any other type of glue or adhesive may not be used in place of wheel clips to hold wheels or axles in place.

- All contest entries will be judged according to the Dragster Design rating sheet, which includes criteria for drawing, design, race, speed, etc.
- No repair or maintenance on entries will be allowed after entries have been registered. Undamaged wheels which come off during the contest may be replaced as determined by the event coordinator. Damaged wheels may not be replaced.
- Any entry damaged during the race will be evaluated by the event coordinator to determine whether or not the vehicle is allowed to race again.
- In the event that the entry is damaged by conference personnel during evaluation or the race, the event coordinator will rule as to whether the vehicle may be repaired by the student entering the vehicle. This is the only reason a student is allowed to touch his/her vehicle after registration.

## **VI. PROCEDURE**

- Contestants will register their dragsters with the Competitive Events Coordinator at the designated registration time.
- Instructions and contest time lines provided at registration will be followed. It will be the responsibility of each contestant to obtain these for each conference.
- At the time of registration, each dragster will be assigned an entry number. This number will be attached to the dragster by conference personnel who are working in the exhibit area.
- Races for each level of competition will be run separately. Each entry will race two (2) times. The better time for each entry will be counted for final evaluation of the dragster. All races for each level of competition will be run on the same side of the track.

## **VII. REQUIRED CONTEST PERSONNEL AND EQUIPMENT**

- Contest coordinator
- A team of judges - ideally three but fewer are acceptable each entry will first be checked to be sure it meets the required specifications, qualifying entries will then be judged on design, drawing, and construction.
- Person assigned for security during registration
- Tables for entries
- Room or area to run the race
- Room or area to secure dragster entries
- 20-meter track with starting gate and timer
- CO2 cartridges - three (3) per entry plus spares

## VIII. CRITERIA FOR JUDGING

- Entries shall be judged on design, drawing, and construction/craftsmanship. These three areas along with its race results will determine the final standing of each dragster. Judges will complete their evaluation of each entry without consultation with the other judges.
- Ratings shall be based upon the following:

Design ..... 16 points

- Appearance - 8 pt.
- Finish - 8 pt.

Drawing ..... 20 points

- Accuracy - 10 pt. (Dragster will be compared to the drawings and specifications)
- Neatness - 2 pt.
- Dimension accuracy - 2 pt.
- Point-to-point contact of arrow heads, extension lines, corner, etc. - 2 pt.
- Line quality - 2 pt.
- Irregular curves - 2 pt.

Construction/Craftsmanship ..... 14 points

### Race

1st Place	60 points
2nd Place	56 points
3rd Place	52 points
4th Place	48 points
5th & 6th Place	45 points
7th & 8th Place	40 points
9th - 12th Place	35 points
13th - 16th Place	30 points
17th - 24th Place	25 points
25th - 32nd Place	20 points

The Contest Coordinator will provide the Competitive Events Coordinator with a sealed packet containing the results.

All judge's ratings and results are to remain confidential.

## ENGINEERING DESIGN

### OVERVIEW

Participants work as part of a team to design and fabricate a device that will solve a problem. Generally, the theme for engineering design is provided by National TSA. The theme for this year's engineering design is Advance Health Informatics.

### PURPOSE

Participants apply the principles and practices of engineering and universal design to develop an effective and practical solution to a specific design problem that they have identified. The solution incorporates the application of scientific and mathematical principles and concepts; demonstrates the application of technology; and assesses the impact of the solution on an individual with a specific disability, and on society.

### ELIGIBILITY

There is no level for this competition, meaning that all participants will compete against one another. Chapters are limited to two (2) teams of three to five (3-5) students.

### REGULATIONS

- A. Each team is required to secure the assistance and support of a team mentor—someone other than the TSA advisor. The name, address, and occupation of this individual is to be documented and included in the specified place in the team's documentation portfolio.
- B. The entire solution (including model/prototype, design portfolio, display materials) must not exceed 15" deep x 3' wide x 4' high.
- C. Documentation materials (comprising "a portfolio") are required and should be secured in a clear front report cover. The report cover must include the following single-sided, 8 ½" x 11" pages, in this order:
  1. Title page with the event title, the conference city and state, and the year; one (1) page
  2. Table of contents; pages as needed
  3. Mentor verification that includes the name, address, and occupation of the mentor; one (1) page.
  4. A design brief (format that follows) that describes the design and its constraints; one (1) or more pages

### DESIGN BRIEF

- Context Task: States the nature of the engineering design; Clearly states what the team will be involved in

- Restrictions: Identifies any restrictions
  - Investigations: Identifies the research involved
  - Development: States essential elements involved in planning
  - Production: Identifies the expected result
  - Evaluation: Identifies the expected assessment procedure and criteria
5. A description of the problem solving steps; pages as needed
  6. Plan of Work log that indicates preparation for the event, as noted by date, task, time involved, team member responsible and comments (see Plan of Work log); one (1) page
  7. Evidence of research conducted by the design team; pages as needed
  8. Documentation of brainstorming; pages as needed
  9. Descriptions and illustrations of a minimum of three (3) possible solutions with a brief, but concise, evaluation of the merits of each; three (3) or more pages
  10. A detailed description of the final solution, including an explanation of the steps of operation; pages as needed
  11. A three (3)-dimensional technical or CAD drawing and/or rendering of the final solution; the maximum sheet size is drawing sheet cut size B—11" x 17"; when this sheet size is used, the sheet must be hole-punched and folded or placed in a sheet protector for insertion in the portfolio; pages as needed
  12. Math and science concepts and applications involved in the final design solution; one (1) page
  13. Explanation of the areas of technology that are an integral part of the solution, including as many as apply; pages as needed
    - a. Medical technology
    - b. Agriculture and biotechnology
    - c. Energy and power
    - d. Information and communication
    - e. Transportation
    - f. Manufacturing
    - g. Construction



14. A list of references and resources; APA or MLA style must be used in citing all references and resources; pages as needed

15. An evaluation of how well the final solution addresses the identified problem/disability and an explanation of the impact of the solution on society and on the identified disability; pages as needed

D. The static display must not require the use of electricity for review and evaluation by the judges.

### **EVALUATION**

Evaluation is based on the documentation of the team's work on the challenge, the display, and the model/prototype.

## IMAGING TECHNOLOGY

OVERVIEW: Participants capture images and process photographic and digital prints for display on a standard sized poster board (18" x 24" or 22" x 28") that depicts the current year's published theme. One entry per student (unlimited entries from chapter) is allowed for this competitive event. **This event is completed at the home school and brought to the state conference for judging.**

### I. CONTEST PURPOSE

The purpose of the Imaging Technology contest is to provide a means for IL-TSA members to demonstrate their ability to communicate through the use of photography. Text can be utilized to further communicate their idea but should be kept to a minimum. **Each contestant must photographically display pictures of the following theme: Forced Perspective, Long Exposure, Architectural, and Abstract Photography (incorporate one photo using each of these types of photography in the portfolio).** For example, the color image may be forced perspective, the black and white may be long exposure, etc.. Identify the type selected for each photo in the written description.

### II. ELIGIBILITY FOR ENTRY

- All IL-TSA members in good standing are eligible to enter the Imaging Technology contest.
- One entry per student (unlimited entries from chapter) is allowed for this competitive event.

### III. LEVELS OF COMPETITION

There are two levels of competition in the Imaging Technology contest

### IV. TIME LIMITATIONS

This is not a "timed" event. The only restriction is that the entries must be submitted at the time specified for registration at each conference.

### V. SPECIFIC REGULATIONS

- The Imaging Technology contest is an individual event. Entries should be the result of one member rather than a group.
- All photos/pictures should be originally taken by the contestant, not taken from another source, e.g., from the Internet.

### VI. PROCEDURES

- Contest participants must register for this event in accordance with procedures established for each conference.
- At registration, each entry will be given an entry number by the contest coordinator. No other identifying marks will be allowed on the entry.
- No designs may be picked up before the designated time.



## MARINE CHALLENGE

OVERVIEW: TSA members entering the Marine Challenge event will design and construct a model marine vessel and/or vessel hull to be tested for payload strength and speed. This event is completed at the home school and brought to the state conference for judging/testing.

### I. CONTEST PURPOSE

The purpose of the Marine Challenge Contest is to provide a means for TSA members to demonstrate their ability to design and fabricate a vessel after having been provided design guidelines.

### II. ELIGIBILITY FOR ENTRY

- All IL-TSA members in good standing are eligible to enter the Marine Challenge Contest.

### III. LEVELS OF COMPETITION

One entry per student (unlimited entries from chapter) is allowed for this competitive event. There are two (2) levels of competition in the Marine Challenge, Level I (grades 6-9) and Level II (grades 10-12), as described in the General Rules.

### IV. TIME LIMITATIONS

None.

### V. SPECIFIC REGULATIONS

- The vessel design must not be larger than 6" wide x 10" long x 2.5" deep
- The vessel must have a 1/4" diameter eye hook secured to the front, which is directly in the center – this eye hook is used to pull the vessel along a path.
- Must have a dedicated area to "hold the payload", which will not weigh more than one pound and will be contained in an area 3" x 3".

### VI. PROCEDURE

- Teams must be registered in accordance with procedures established for each conference.
- All teams will construct their boat entries at the same time.
- Teams may test and redesign their boats until the two hour time limit has expired.
- No additional work may be done after the time limit has expired. All entries will be turned over to the judges for evaluation and testing.
- Boats shall be selected at random for testing.

## **VII. REQUIRED CONTEST PERSONNEL AND EQUIPMENT**

- Contest Coordinator
- A team of judges - ideally three, but fewer are acceptable
- Stop watch to time event
- Reserved space for the testing equipment
- Testing equipment
  - Portable water tank
  - Water
  - All other necessary testing equipment will be provided
  - Calculator
- Evaluation forms

## **VIII. CRITERIA FOR JUDGING**

The winner in this event is determined by the time required to travel a specified distance when a force is applied. The distance and force remain the same for all entrants. The variable is the design of the vessel hull.

## PREPARED PRESENTATION

OVERVIEW: TSA members entering the Prepared Presentation Contest deliver an oral presentation not shorter than three minutes, but no longer than five minutes that includes audio and/or visual enhancement **based on the following theme: "2024 National TSA Conference Theme, "Evolution of Excellence"**.

### I. CONTEST PURPOSE

The purpose of the Prepared Presentation Contest is to assist students in preparing for developing and delivering a prepared presentation in front of an audience/panel of judges.

### II. ELIGIBILITY FOR ENTRY

Two individuals per chapter are allowed for this event.

### III. LEVELS OF COMPETITION

There are two (2) levels of competition in the Prepared Presentation Contest, Level I (grades 7-9) and Level II (grades 10-12), as described in the General Rules.

### IV. TIME LIMITATIONS

- Entries must be started and completed during the current school year.
- Each presentation must be no less than three (3) minutes and no more than five (5) minutes.
- A maximum of four (4) minutes is allowed for set-up.
- At the conclusion of the presentation, the participant must remove all materials within three (3) minutes.
- All students entered in the Prepared Presentation Contest will be assigned an appointment time and place for their interview. It is the responsibility of the student to be on time for his/her appointment.

### V. SPECIFIC REGULATIONS

- Participants report to the event area at the time and place stated in the conference program to receive an assigned presentation time.
- Participants will report to the holding area, as stated in the conference program, fifteen (15) minutes prior to the assigned presentation time.
- The event coordinator introduces each participant by number and in order of scheduled times. The schedule allows time for set-up and removal of materials.

- No observers are allowed in the event or preparation rooms during heats, although they are allowed to sit in the audience of the performance during the finals. No talking or gesturing is permitted. Observers are NOT allowed to enter or leave during a presentation. THERE IS NO APPLAUSE UNTIL THE PRESENTATION HAS CONCLUDED. No form of visual recording (such as photographic or video) or audio recording by any observer (including family, friends, or advisors of the participants) is permitted.
- Each presentation must be the result of the participant's own efforts.
- The presentation must include the use of audio and/or visual media materials.
- Examples of the audio/visual materials may include but are not limited to:
  - Charts and graphs
  - Posters
  - Displays
  - Flip charts
  - Transparencies
  - Models
- Participants are not allowed to hear other participants' presentations.
- A computer and projector will be available for use. Participants will need to have their presentations saved on a flash drive to be placed on the TSA computer.
- An easel and a white background for a projection device are provided by TSA.
- Participant scores are penalized one (1) point per ten (10) second interval for speaking over or under the allotted time. The same penalty is used for set-up and takedown. Time commences when the presentation begins.

## **VI. EVALUATION**

Evaluation is based upon the quality of the presentation and the appropriate use of audio/visual materials.

## VII. REQUIRED CONTEST PERSONNEL AND EQUIPMENT

- Coordinator's notebook, containing:
  - Event guidelines, one (1) each for coordinator and evaluators
  - Official rating forms
  - List of entries with finalist report
  - List of evaluators/assistants
  - Marking pens or pencils for each evaluator
  - Semifinalist list for posting
  - One (1) stopwatch for each event room
  - Results envelope
- Podium, easel, and white background for projection
- Tables and chairs for three (3) evaluators
- Chairs for audience
- One (1) table, approximately 6' long, for participant's use
- Contest coordinator
- Two (2) judges
- Area or room that will house a computer and projector and/or poster board materials

## VIII. CRITERIA FOR JUDGING

### **Presentation (70 pts.)**

Introduction (interest and appeal) - 10 pts.

Knowledge of material (factual support) - 15 pts.

Organization (clarity and sequence) - 15 pts.

Stage presence (personal appearance, poise, posture, attitude, personality, and confidence) 10 pts.

Voice/language (grammar, pitch, pronunciation, articulation, and clarity) 10 pts.

Conclusion - 10 pts.

### **Use of audio/visual materials (30 pts.)**

Creativity in use - 10 pts.

Quality of materials - 10 pts.

Transitions between media use - 10 pts.

### **Time deduction**

One (1) point per ten (10)-second interval over or under the time allotted for the presentation, and the set-up and take-down.

Total 100 Points



## PROMOTIONAL GRAPHICS

OVERVIEW: TSA contestants in the Promotional Graphics Contest develop computer-generated graphic design that can be used to address the following **Theme: Develop promotional materials for a leadership development program for high school students. The program will consist of 6, two-hour sessions that will be held on the 2nd Tuesday of five-consecutive months. You will need to design and produce recruitment documents for students, a flyer, and an application.**

**This event is completed at the home school and brought to the state conference for judging.**

### I. CONTEST PURPOSE

Participants have the opportunity to use computerized graphic communications layout and design skills in the production of a promotional resource for TSA.

### II. ELIGIBILITY FOR ENTRY

- One entry per student (unlimited entries from chapter) is allowed for this competitive event.
- All IL-TSA members in good standing are eligible to enter the contest.

### III. LEVELS OF COMPETITION

There are two (2) levels of competition, Level I (grades 6-9) and Level II (grades 10-12) as described in the General Rules.

### IV. TIME LIMITATIONS

This is not a "timed" event. The only restriction is that the entries must be submitted at the time specified for registration at each conference.

### V. SPECIFIC REGULATIONS

- The Promotional Graphics contest is an individual event.
- The title of the design must be incorporated into the graphic.
- Captions under graphics may be used for identification purposes only. Captions should not be used to help tell the story, as the graphics should be telling the story or describing the place.
- Specific requirements for each level of competition will be made available to members prior to each conference.
- References (source) are required for non-original images.

### VI. PROCEDURES

- Contest participants must register for this event in accordance with procedures established for each conference.

- Entries must be entered during the designated contest registration time. Late entries will not be accepted.
- At registration, each entry will be given an entry number by the contest coordinator. No other identifying marks will be allowed on the entry.
- No entries may be picked up before the designated time.

#### **VII. REQUIRED CONTEST PERSONNEL AND EQUIPMENT**

- Contest coordinator
- A team of judges - ideally three but fewer are acceptable
- A copy of the contest guidelines
- Judge's rating sheets
- Pens and pencils
- Display area for entries, may be tables or may hang on wall
- Tape or push pins for displaying entries

#### **VIII. CRITERIA FOR JUDGING**

Entries shall be evaluated using the following criteria.

##### **Impact (15 pts)**

Effective communication of conference theme - 5 pts.

Appropriateness of design - 5 pts.

First impressions (sharp clean edges of graphics and fonts; entry is clear of smudges, smears, pencil or other extraneous marks) - 5 pts.

##### **Graphic (15 pts)**

Graphic is appropriate for stated theme - 10 pts.

Fonts are readable, have eye appeal, appropriate dimension and placement - 5 pts.

[References are required for non-original or copyrighted image(s).]

##### **Design elements (40 pts)**

Balance (visual weight of design elements) - 10 pts.

Dominance (eyes are drawn to main message) - 10 pts.

Proportion (size relationships within the design) - 10 pts.

Unity (design elements flow together) - 10 pts.

Rules violation (must be initialed by coordinator and manager) .....minus 20% of the total possible pts.

70 Points

## **SAFETY IN TECHNOLOGY**

OVERVIEW: The Safety in Technology contest is designed to direct attention to the area of technological safety. Contestants develop a graphic design(s) that communicates safety in a technological field. Submissions must be on 11" x 17" paper and/or poster board. **This event is completed at the home school and brought to the state conference for judging.**

### **"Cyber Security"**

#### **I. CONTEST PURPOSE**

The purpose of the Safety in Technology contest is to provide a means for TSA members to demonstrate their ability to recognize safety needs and to communicate safety messages in visual form.

#### **II. ELIGIBILITY FOR ENTRY**

- All IL-TSA members are eligible to enter the Safety in Technology Contest.
- There is no limit to the number of entries per chapter.

#### **III. LEVELS OF COMPETITION**

There are two (2) levels of competition, Level I (grades 6-9) and Level II (grades 10-12) as described in the General Rules.

#### **IV. TIME LIMITATIONS**

This is not a "timed" event. The only restrictions are that the posters must be completed prior to the state conference and that they must have been done during the present school year.

#### **V. SPECIFIC REGULATIONS**

- No member may enter more than one (1) poster.
- The Safety in Technology poster must be produced on 11 x 17 paper or poster board. Posters must be of a hanging type which can be mounted on a wall for exhibition.
- Contestants must not leave posters until entry numbers have been affixed to the back of the poster by an official. The entry number will be assigned during contest registration. The contestant's name, school, etc. must not appear anywhere on the poster.



## STRUCTURAL ENGINEERING – Truss Design

OVERVIEW: Participants design and construct a model structure that is destructively tested to determine design efficiency. **This event is completed at the home school and brought to the state conference for judging/testing.**

### I. CONTEST PURPOSE

The purpose of the Structural Engineering Contest is to provide a means for TSA members to demonstrate their ability to design and fabricate a structure after having been assigned span and width specifications.

### II. ELIGIBILITY FOR ENTRY

- All IL-TSA members in good standing are eligible to enter the Structural Engineering Contest.
- One entry per student (unlimited entries from chapter) is allowed for this competitive event.

### III. LEVELS OF COMPETITION

There are two (2) levels of competition in the Structural Engineering Contest, Level I (grades 6-9) and Level II (grades 10-12), as described in the General Rules.

### IV. TIME LIMITATIONS

Since the structural artifacts are constructed prior to the state conference, there is no time limitation other than the artifacts must have been constructed during the current school year.

### V. SPECIFIC REGULATIONS –

- Trusses must be constructed according to specifications.
- Trusses must be constructed according to the following definitions and graphic illustrations which are an integral part of the contest regulations.
- **Span: The overall span of the truss must be 12".**
- **All stock used to construct the truss may only have adhesive at joints (no adhesive spread over or coating of stock is allowed).**
- **Materials:** The amount of basswood or balsa wood 1/8" x 1/8" or 3/32" x 3/32" stock is unlimited and one 3" x 5" note card may be used to construct the truss. Any type of liquid adhesive can be used in the construction of the truss.
- The structure must include 2 or 4 individual trusses, attached together to create the truss structure, but must not be wider than 3".
- **Lamination:** Two pieces of 1/8" x 1/8" or 3/32" x 3/32" stock glued together surface-to-surface with the wood grain running parallel. Lamination of more than two pieces is not permitted.

## CORRECT LAMINATION



## INCORRECT LAMINATION



**Failure Weight:** The greatest weight recorded during testing before failure of the structure. Failure to comply: If a structure fails to comply with any regulation, a penalty reduction of twenty percent (20%) of the greatest weight held in the contest is subtracted from the individual's failure weight.

**Gusset:** A panel or bracket attached to corners or intersections of truss components to add strength or stiffness. Note cards may be cut and used as gussets to strengthen the joints of truss structures. Note card gussets on trusses are to be no larger than the diameter of a current issue American quarter dollar coin. The gussets may not touch another note card gusset or overlap other trusses. They may not be sandwiched between two (2) laminated members.

The tester will be set at 10" for the 12" truss.

**The roof truss will need to be fabricated on a 5/12 slope.** This simply means that the truss would rise vertically 5 units for every 12 units of horizontal run.

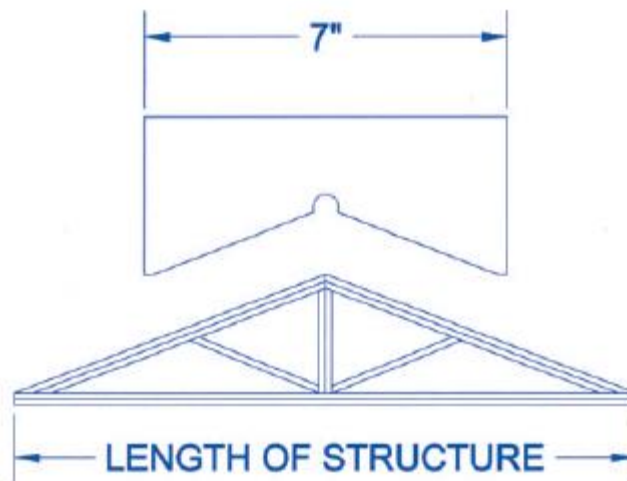

No part of the structure may extend below the bottom chord of the truss.

Truss members to simulate decking may be used above the truss to add stability. Internal members may be used to simulate cross bracing but be certain to avoid blocking the center (the location of the testing rod). **An opening of  $\frac{1}{2}$ " x  $\frac{1}{2}$ " must be present in the design in order for the truss to be tested correctly.**

The roof truss must be a triangle.

The peak of the truss is to be centered in the length of the truss.

## VII. REQUIRED CONTEST PERSONNEL AND EQUIPMENT

- Contest Coordinator
- Assistant to help with testing

- Testing equipment
  - Appropriate testing equipment will be supplied
  - Scales
  - Calculator
- Evaluation forms

### VIII. CRITERIA FOR JUDGING

- The structure is weighed before testing and the weight is recorded on the evaluation form.
- An increasing load is applied to the structure via the test block until the structure fails.
- The failure weight is recorded on the evaluation form.
- The efficiency is determined by the failure weight x 4.54 divided by the weight of the structure in grams.
- The efficiency is rounded off to three (3) decimal places and recorded on the evaluation form.
- The highest numeric efficiency is the winner. In case of an efficiency tie, the greatest weight held by the tied entries will be declared the winner.
- Structures that violate guidelines will receive a deduction of 20% of the greatest weight held for the first violation.
- Structures are not to be tested if
  - there are two (2) or more rule violations.
  - the structure cannot be placed on the tester.
  - the testing hook cannot be placed in the center of the structure.
  - straight pins are left in the structure.
  - there is a failure to wear safety eyewear.
  - there is evidence of conduct unbecoming a TSA conference participant during check-in, fabrication, or testing.

The structure is destructively tested using the breaker block shown below.

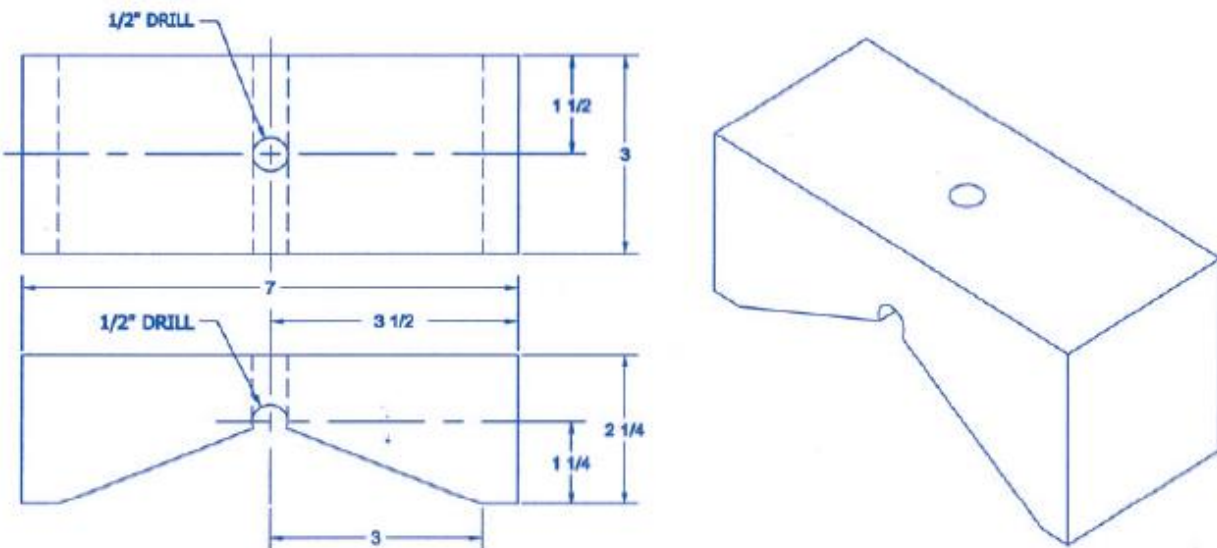

## STRUCTURAL ENGINEERING – Bridge Design

OVERVIEW: Participants design and construct a model structure that is destructively tested to determine design efficiency. **This event is completed at the home school and brought to the state conference for judging/testing.**

### I. CONTEST PURPOSE

The purpose of the Structural Engineering Contest is to provide a means for TSA members to demonstrate their ability to design and fabricate a structure after having been assigned span and width specifications.

### II. ELIGIBILITY FOR ENTRY

- All IL-TSA members in good standing are eligible to enter the Structural Engineering Contest.
- One entry per student (unlimited entries from chapter) is allowed for this competitive event.

### III. LEVELS OF COMPETITION

There are two (2) levels of competition in the Structural Engineering Contest, Level I (grades 6-9) and Level II (grades 10-12), as described in the General Rules.

### IV. TIME LIMITATIONS

Since the structural artifacts are constructed prior to the state conference, there is no time limitation other than the artifacts must have been constructed during the current school year.

### V. SPECIFIC REGULATIONS –

- Bridges must be constructed according to specifications and only utilize 1/8" x 1/8" or 3/32" x 3/32" balsa or basswood.
- Bridges must be constructed according to the following definitions and graphic illustrations which are an integral part of the contest regulations.
- BRIDGE LENGTH: The overall length of the bridge may not exceed 14" (span + 1" minimum, 2" maximum). **All bridges must be between 12"-14" long.**
- SUPER-STRUCTURE: The structure of the bridge which extends above the roadbed. The maximum width of the super-structure is 5 inches.
- SUB-STRUCTURE: The structure of the bridge which extends below the roadbed. The sub-structure may be no longer than 9", 3" tall, and 5" wide, and must be centered crosswise under the roadbed.
- SPAN: The distance between bridge supports.



- **TEST BLOCK:** That piece of test apparatus to which the testing rod (1/2" Diameter) is attached to the testing machine. The length of which will be 2" less than the span. See Diagram C.
- **ROADBED:** The part of the bridge that is meant to be traveled upon. The roadbed must be maintained at a minimum width of 3" inside the supports. The bridge must be constructed to allow the test block and testing rod to pass through the bridge opening on the roadbed from one end to the other. Roadbed cannot be constructed from a single piece of stock and cannot exceed 1/4" thickness.
- **FAILURE:** Once the test load is placed upon the bridge, failure is determined by one of the following:
  - the bridge collapses, or
  - any part of the sub-structure touches the bridge support systems.
- **LAMINATION:** Two pieces of 1/8" x 1/8" or 3/32" x 3/32" stock glued together surface-to-surface with the wood grain running parallel. Refer to Diagram B below for examples of correct and incorrect laminations.

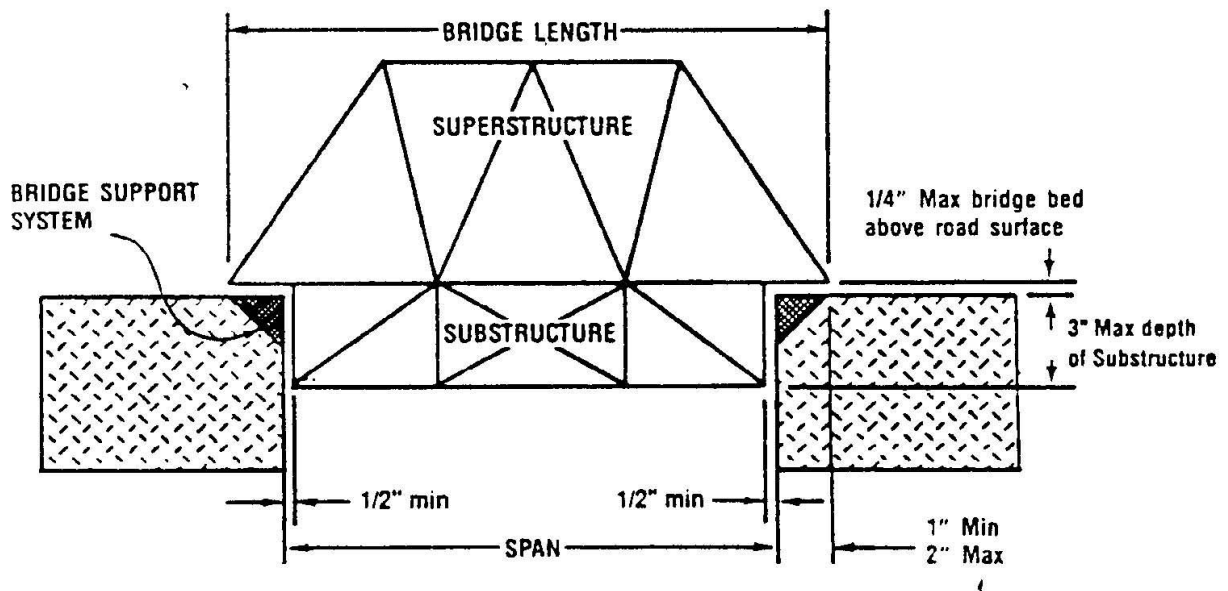
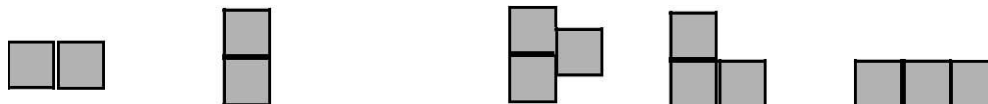

DIAGRAM A



CORRECT LAMINATIONS

INCORRECT LAMINATIONS

## DIAGRAM B

- **Bridges must be constructed in such a manner as to accommodate the test block and rod at the bridge's center.** The roadbed of the bridge must be free of obstructions.
- Coating of laminated beams with glue will not be permitted.

### VI. PROCEDURE

- Bridge entries must be registered in accordance with procedures established for each conference.
- Bridge entries will be entered for competition along with all other exhibits during conference registration.
- All bridges will be evaluated by judges to determine their qualification for competition. Only qualified bridges will be tested in competition.
- Security shall be provided for all bridge entries as for all other exhibits.
- Bridges shall be selected at random for testing.

### VII. REQUIRED CONTEST PERSONNEL AND EQUIPMENT

- Contest Coordinator
- Assistant to help with testing
- Testing equipment
  - Appropriate testing equipment will be supplied
  - Scales
  - Calculator
- Evaluation forms

### VIII. CRITERIA FOR JUDGING

- Method to be used with a bridge testing machine.
  - Bridge efficiency shall be determined by the following formula:
  - Dividing the failure weight (Load) by the bridge weight
  - The structure will be weighed and the weight entered into the formula as "Weight of Structure (grams)."

- An increasing load will be applied to the bridge via the bridge tester until the bridge fails. The reading on the tester gauge will be entered in the formula as "Load."
- The bridge with the highest efficiency number is the winning bridge.
- All efficiency ratings shall be calculated to three (3) decimal places. The highest efficiency rating will be the winner. In the event of a tie, the efficiency rating will be calculated to the next decimal point until a winner is decided.
- An increasing load will be applied to the bridge via the test hook (Diagram C) until the bridge fails. The load will be weighed and the weight entered in the formula as the "Failure Weight."

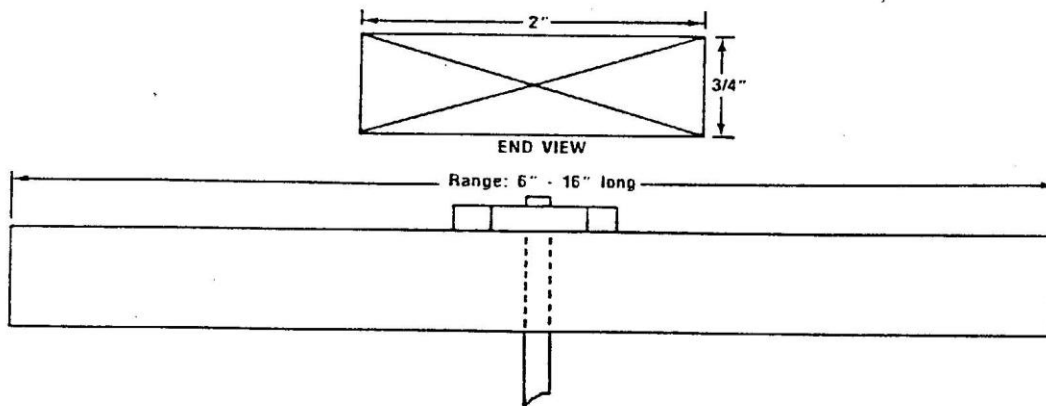

**DIAGRAM C**

## TECHNICAL DESIGN

OVERVIEW: TSA contestants in Technical Design demonstrate their technical knowledge of drafting by completing a written test and solving an engineering graphics problem (multi-view drawing) using standard board drawing techniques.

### I. CONTEST PURPOSE

The purpose of the Technical Design contest is to provide a means for TSA members to demonstrate their knowledge and abilities in drafting.

### II. ELIGIBILITY FOR ENTRY

- All IL-TSA members in good standing are eligible to enter the Drafting contest.
- Entries are limited to two (2) per chapter.

### III. LEVELS OF COMPETITION

There are two (2) levels of competition in the Technical Design Contest, Level I (grades 6-9) and Level II (grades 10-12), as described in the General Rules.

### IV. TIME LIMITATIONS

The length of time allowed for the completion shall be 1 ½ hours.

### V. SPECIFIC REGULATIONS

- The Technical Design contest is an individual event.
- All materials for the written test will be provided at the conference.
- All drawings shall be done on 9" x 12" drafting paper. Paper shall be provided at the conference.
- **All entrants shall provide their own drafting equipment.**
- All lettering on the drawing shall be free hand. No lettering guides or devices shall be allowed. Guidelines for lettering may be used.
- All drawings shall be done in pencil. No inking of drawings shall be allowed. Contest participants may bring their own pencils or use pencils provided. Only No. 2 (HB) lead pencils will be available at the conference.

## **VI. PROCEDURES**

- Contest participants must register for this event in accordance with procedures established for each conference.
- Contestants must be at the assigned testing area before the established starting time for the event.
- Once the event has started with the distribution of the written test or the problem, no additional contestants will be allowed to enter the testing area.
- Contestants will not be allowed to leave the testing area and return after the event has begun.
- Contestants may leave the contest area when they have completed the written test and drawing.
- All drawing problem sheets and drawing entries shall be turned in to the contest coordinator.
- All drawing equipment must be removed from the testing area upon the completion of the event.

## **VII. REQUIRED CONTEST PERSONNEL AND EQUIPMENT**

- Contest coordinator
- A team of judges - ideally three but fewer are acceptable
- A copy of the contest guidelines
- Written tests, pencils, and answer sheets
- Drawing paper, copies of problems, and correct solutions
- Judge's rating sheets
- Pens for judges
- Tables and chairs for contestants

### VIII. CRITERIA FOR JUDGING

- Drafting Contest entries shall be evaluated using the following criteria.

#### LEVEL I

Accuracy of solution	25 points
Placement of views	15 points
Accuracy of Drawing	25 points
Lettering	10 points
Line quality	15 points
Neatness and appearance	10 points
Written test score	100 points
TOTAL	200 points

#### LEVEL II

Accuracy of solution	25 points
Placement of views	10 points
Accuracy of Drawing	20 points
Dimensioning fundamentals	10 points
Lettering	10 points
Line quality	15 points
Neatness and appearance	10 points
Written test score	100 points
TOTAL	200 points

- Awards

First, Second, and Third place awards will be presented in each level of competition.

## **TECHNOLOGY BOWL - ORAL**

OVERVIEW: Chapter teams entering this event will compete with other teams in a verbal question and answer contest.

### **I. CONTEST PURPOSE**

The purpose of the Technology Bowl - Oral contest is to provide TSA members with the opportunity to work together in teams to demonstrate their knowledge of technological content.

### **II. ELIGIBILITY FOR ENTRY**

- All TSA members in good standing are eligible to enter the Technology Bowl - Oral contest.
- Entries are limited to one (1) five-member team per chapter.

### **III. LEVELS OF COMPETITION**

There are two levels of competition in the Technology Bowl - Oral event.

### **IV. TIME LIMITATIONS**

Teams must be available as scheduled for the oral competition or the team will be disqualified.

### **V. SPECIFIC REGULATIONS**

- Questions used will be alternately selected at random from the seven content areas of the Standards for Technological Literacy.
- No transmitting or recording devices shall be permitted in the contest area. No prompting shall be permitted.
- A total of five questions will be asked per round. No questions will be repeated in another round.
- A match consists of 5 toss-ups and a possibility of 5 bonus questions (A bonus question is only read when a toss-up is answered correctly by either team).
- A correctly answered toss-up is worth 10 points (No negative points for an incorrect response).
- The team that answers the toss-up correctly gets the first chance at answering the multiple-part bonus question. After the bonus question is read, the team has 30 seconds to confer. If the first team does not answer all parts, the other team gets a chance to answer the remaining parts.
- Bonus questions will have 3-4 answers/parts, with each part worth 5 points.
- If there is a tie after the set amount of toss-up questions and bonus questions, one extra toss-up will be asked. An incorrect response will result in the opposite team winning the match
- In case of a tie, at least one (1) additional question will be asked until a winner is determined.

- After a question is read, the competing teams will have ten (10) seconds to "buzz in." If neither team can answer the question, another question will be read.
- If a team member "buzzes in" before the question is completed, that team has five (5) seconds to give the correct answer without hearing the remainder of the question. If an incorrect answer is given, the question will be repeated for the other team.

## **VI. PROCEDURE**

- Contest participants must register and follow the guidelines for this event in accordance with procedures established for each conference.
- The initial order of participation shall be established by a drawing of team numbers prior to the beginning of the contest.
- After instruction briefing, team members will report to the holding room as designated. Teams will remain in the holding room until called for competition or eliminated. Teams may visit with other teams, however, no advisor or visitors may come into the holding room.
- When instructed to do so, two teams will enter the contest area and be seated according to instructions.
- Team members will not be allowed in the contest area as observers until after the team has been eliminated.
- Once a team is eliminated, it is eliminated entirely.
- Questions will be prepared, by round, prior to the beginning of the contest.
- If equipment malfunctions, the question being asked will automatically be disqualified. A new question will not replace the disqualified question.
- If equipment malfunctions three (3) times during the same round, time will be called by the Contest Coordinator to set up the back-up equipment. After the new equipment has been set up and tested, the contest will continue from the point where it stopped.

## **VII. REQUIRED CONTEST PERSONNEL AND EQUIPMENT**

- Contest coordinator
- Timekeeper
- Moderator
- Table with a rostrum for the moderator
- Two tables and six chairs for the contest teams
- List of chapters entered in the contest



- Lights and controls for contestant's tables
- Chalkboard
- Test questions - questions should be previously selected for rounds before the contest begins
- Several sets of tie-breaker questions previously selected

### **VIII. CRITERIA FOR JUDGING**

A team's score is derived from the total correct answers to the questions asked. For each correct answer, the team will receive ten (10) points. If a question is answered incorrectly, or if a member of a team presses a button and cannot answer the question, five (5) points are subtracted from the team's total points. The team with the higher number of points will continue to the next round of competition while the losing team is eliminated from the competition.

## **TECHNOLOGY BOWL - WRITTEN**

OVERVIEW: TSA members entering the Technology Bowl-Written contest will complete a written objective examination covering many aspects of Technology Education.

### **I. CONTEST PURPOSE**

The purpose of the Technology Bowl - Written contest is to allow students the opportunity to demonstrate their knowledge of technical content in a wide variety of technology areas.

### **II. ELIGIBILITY FOR ENTRY**

- All TSA members in good standing are eligible to enter the Technology Bowl - Written contest.
- Unlimited contestants per chapter.

### **III. LEVELS OF COMPETITION**

There are two levels of competition in the Technology Bowl - Written contest.

### **IV. TIME LIMITATIONS**

- The written test will be administered to all students entering this contest at the same time.
- One (1) hour will be allowed for this test.

### **V. SPECIFIC REGULATIONS**

- All necessary materials including pencils, tests, answer sheets, etc. will be provided by the Contest Coordinator. Contestants should bring nothing with them to the testing room.
- Contestants who are not present when the test is distributed will be disqualified and restricted from the test area.
- The test will consist of 100 objective questions including true - false and multiple choice.
- The test will cover the Standards for Technological Literacy.
- Contestants must stop work immediately when time is called by the Contest Coordinator.
- Should a contestant complete the test before the time allocated expires, the contestant will hold his test paper and remain seated quietly without distracting anyone else. Failure to do so may result in disqualification of the contestant at the discretion of the Contest Coordinator.
- All test papers must be turned in before leaving the test area.

**VI. PROCEDURE**

- All contestants in the Technology Bowl-Written event must register at the designated time and follow the guidelines and procedures established for each conference.
- Contestants must be at the assigned testing area before the established starting time for the test.
- All contestants will follow the Specific Regulations and adhere to all directions provided on site by the Contest Coordinator.

**VII. REQUIRED CONTEST PERSONNEL AND EQUIPMENT**

- Contest coordinator
- Person to time the test (may be the Contest Coordinator)
- Three (3) to five (5) judges for grading or computer grading facilities
- A stopwatch
- Tables and chairs or armchairs in sufficient quantity to accommodate all contestants
- A room large enough to accommodate all contestants
- Rating sheets for the judges
- Pencils for all contestants
- Test booklets and answer sheets
- Contest results reporting form

**VIII. CRITERIA FOR JUDGING**

The most correct answers on the written test will determine the winners in this event.

## **TECHNOLOGY PROBLEM SOLVING**

OVERVIEW: TSA teams entering the Technology Problem Solving event are required to use a team approach to provide an adequate solution to a given problem within a specified and limited time frame. Design, function, cooperative teamwork, and originality are the primary elements judged.

### **I. CONTEST PURPOSE**

The purpose of the Technology Problem Solving contest is to provide students with an experience in problem solving. Students working in teams of three will use critical thinking skills in order to develop a satisfactory solution to the stated problem.

### **II. ELIGIBILITY FOR ENTRY**

- All IL-TSA chapters in good standing are eligible to enter the Technology Problem Solving contest.
- All members of each team must be in the same level of competition as stated in the General Rules.
- Entries are limited to two teams of two individuals, per level, per chapter.

### **III. LEVELS OF COMPETITION**

There are two (2) levels of competition in the Technology Problem Solving contest, Level I (grades 6-9) and Level II (grades 10-12), as described in the General Rules.

### **IV. TIME LIMITATIONS**

The allotted time for design and construction of the solution will be one hour-thirty minutes, unless otherwise noted. All contestants in this event must arrive and be in place at the specified time and location.

### **V. SPECIFIC REGULATIONS**

- Teams shall consist of two members. All team members must be in the same level of competition.
- All work must be done in the specified area.
- All materials will be provided. No additional materials will be allowed during construction of the solution.
- All necessary tools will be provided.
- Contestants will be given the problem and judging criteria when entering the contest room. The contest problem and criteria for judging will be available to local TSA advisors after the contest is complete.

- Contest problems will be selected from areas such as, but not limited to:
  - Communication
  - Energy
  - Transportation
  - Production
  - Construction
  - Societal/future
  - Applications of Technology

## **VI. PROCEDURES**

- Contest Participants must register and follow the guidelines for the event in accordance with the procedures established for each conference.
- One team member will check in his/her team with the Contest Coordinator at the time designated for the event to obtain specific information for the event.
- Problem solving teams should assemble in the general area of the contest prior to the designated time for the contest.

## **VII. REQUIRED CONTEST PERSONNEL AND EQUIPMENT**

- Contest coordinator
- A team of judges - ideally three but fewer are acceptable, one can serve as timekeeper
- Stopwatch or clock to time event
- A copy of the contest guidelines
- Judge's rating sheets
- Pencils for judges
- Tables and chairs for the contestants and judges
- Technology problem and judging criteria
- Tools and supplies needed for developing solutions
- Contest results reporting form

### VIII. CRITERIA FOR JUDGING

Technology Problem solving teams shall be rated using the following general criteria:

Creativity 20 points

Is the solution a creative solution to the stated problem?

Function 20 points

Does the solution work? Does it actually fulfill the stated need or purpose of the problem?

Design 20 points

Is the solution well designed and did team members use available materials to their best advantage?

Originality 20 points

Does the solution demonstrate original thinking to solve the problem?

Accuracy 20 points

Does the solution meet the required criteria as stated in the problem?

These criteria areas are general in nature and may change from year to year as the problem dictates. Point totals shall always equal 100 points.



## ACHIEVEMENT PROGRAM

The TSA Achievement Program (bronze, silver, and gold awards) is designed to motivate and recognize student members for high effort in a school's technology education program. The TSA Achievement Program is

- an opportunity for every TSA member to strive and receive recognition for accomplishments;
- designed to encourage excellence in the areas of leadership development, understanding technology, school/community service, and career/personal planning; and
- planned so the highest awards represent outstanding individual performance.

The Technology Student Association Achievement Program provides opportunities for TSA members to attain the highest ideals and goals of TSA. This noncompetitive, self-initiated program encourages students to develop appropriate attitudes and increase their knowledge and skills through involvement in technology education programs and activities.

The basic goals of the TSA Achievement Program are to:

- inspire TSA members to attain the high goals and ideals of TSA;
- promote active participation at the school, community, state, and national levels;
- provide opportunities that assist students in making informed and meaningful career and educational choices;
- develop leadership and team participation abilities; and
- recognize participation in technology education programs and TSA.

### LEVELS

The TSA Achievement Program is composed of three levels of achievement: bronze, silver, and gold. Everyone begins at the bronze level. When a member completes the required activities at the bronze level, s/he is eligible for the appropriate award and for work toward the silver level. Eventually, s/he may work for points toward the gold level.

National TSA recommends working on the Achievement Program over a two-year period of time. The student strives to achieve the Bronze and Silver Awards in one school year, and the Gold Award during the following school year. This time frame is suggested in order to give the appropriate amount of time and effort to the projects/steps that are required to achieve each level and to maximize the learning experience.

### RULES FOR STUDENT MEMBERS

1. In order to participate in the TSA Achievement Program, a student must be an active member in an affiliated, local TSA chapter.
2. The student may choose from the activities listed under the four achievement categories of leadership development, understanding technology, school/community service, and career/personal planning.

3. Each activity must be recorded on an activity resume and initialed by the local chapter vice-president.
4. When a minimum of twenty points has been accumulated in each category, and an additional twenty points from any or all of the categories, the student is eligible to submit the activity resume to the chapter advisor. A total of one hundred points is required to attain each level of achievement.
5. Following recommendation by the chapter vice-president, the chapter advisor verifies successful completion of the activities by signing the activity resume. Resumes for Bronze, Silver, and Gold Awards should be sent to and retained by state advisors. **Resumes for these awards should not be sent to National TSA.**
6. Points are cumulative from one award level to the next. The points earned for the Bronze Award count for the Silver Award, and the points earned for the Bronze and Silver Awards count toward the Gold Award. All points earned, beginning with the Bronze Award, must be listed on the activity resume each time the resume is submitted for a new level.
7. Points may not be claimed for activities prior to TSA membership.
8. Each activity may be claimed only once, unless otherwise indicated.
9. The local chapter vice-president verifies an activity only after the activity has been completed; the local advisor verifies the activity resume once all activities are completed for the appropriate level.
10. The TSA state advisor verifies a student's TSA membership and retains a copy of the activity resume for state files. Activity resumes are not submitted to national TSA.

**All documentation is completed online through a Google Document/Form, which can be found [here](#).  
All applications are due one week before the state conference.**



## LEADERSHIP DEVELOPMENT

The following individual and group leadership development activities are designed to help the student develop the ability to plan, organize, and carry out worthy projects. They encourage the student to become a good leader and follower. Students should select and complete activities totaling a minimum of twenty points.

Code	Points	Completed	Activity
101	5		Meet all chapter deadlines.
102	5		Attend and participate in all chapter meetings.
103	5		Serve on a major committee, such as finance, program of work, nominations, etc.
104	5		Prepare a chapter meeting agenda.
105	5		Prepare a committee meeting agenda.
106	5		Successfully complete a basic parliamentary procedure quiz.
107	5		Lead a class discussion or demonstration.
108	5		Recruit a new TSA member.
109	5		Make and second a minimum of three main motions for passage at chapter meetings.
110	5		Make a minimum of two privileged motions at chapter meetings.
112	5		Debate a minimum of two motions at chapter meetings.
113	5		Hold an office in another organization while a member of TSA.
114	5		Recite (from memory) the TSA motto and creed at a regular TSA business meeting.
115	5		Lead the invocation at a TSA function.
116	10		Serve as a delegate at a regional, state, or national conference.
117	10		Chair one of the major local committees.
118	10		Chair one sub-committee, such as refreshments, entertainment, welcoming, guest speaker, etc.
119	10		Plan and organize one service project.
120	10		Plan and organize one fund raising project.
121	10		Plan and organize one social function.
122	10		Plan and organize one educational/technical activity.
123	10		Serve as a chapter officer.
124	10		Successfully complete an advanced parliamentary exam.
125	10		Lead a session at a district, regional, state, or national conference or convention.
126	10		Give a talk on technology education to a group not familiar with TSA.
127	10		Report to a committee or your chapter officers on: <ul style="list-style-type: none"> <li>• the mascot, colors, and motto of your school</li> <li>• the student council officers of your school</li> <li>• the history of your school</li> <li>• other student organizations in your school and what they do</li> </ul>
128	10		Report to a committee or your chapter officers (for one of the following levels: local, state, or national) on: <ul style="list-style-type: none"> <li>• the purposes of TSA as they are stated in the constitution</li> <li>• the heritage and development of the association</li> <li>• the names of the officers and their responsibilities</li> <li>• the membership requirements of the association</li> </ul>

			<ul style="list-style-type: none"> <li>the times, dates, and places of meetings</li> </ul>
129	10		Attend a state or national TSA leadership conference.
130	10		Assist in the preparation of a state or regional TSA conference.
131	10		<p>Explain to another student organization, student group, technology education class, or civic group about:</p> <ul style="list-style-type: none"> <li>TSA</li> <li>technology education</li> <li>the goals of TSA</li> <li>the benefits of being a member of TSA</li> </ul>
132	15		Serve as a state TSA officer.
133	20		Serve as national TSA officer.

### UNDERSTANDING TECHNOLOGY

The Understanding Technology activities in the TSA Achievement Program emphasize the importance of developing problem solving skills and a knowledge base for success in a technological society. The activities also help students become more aware of the need for following safety procedures and for developing technology skills at home, in the technology lab, in the community, and in business settings. Students should select and complete activities totaling a minimum of twenty points.

Code	Points	Completed	Activity
201	5		Demonstrate the safe use of three pieces of equipment in the technology lab.
202	5		Demonstrate the safe use of ten tools.
203	5		Pass a safety test with 100% accuracy for three pieces of equipment.
204	5		Prepare a classroom/school bulletin board on a technology-related topic.
205			Conduct a study on the safety practices used in the technology lab for a period of two weeks and report on it to the class.
206	5		Make a CAD drawing.
207	5		Write a program for use in the technology lab, i.e., a CNC program, or one that converts inches to millimeters, calculates the cost of a product, etc.
208	5		Write a report on the use of lasers, fiber optics, artificial intelligence, computer control, or super conductors.
209	5		Imagine how society may be revolutionized by technology in the near future and write a report on it.
210	5		Prepare an oral report on the input-process-output-feedback principle of technology practices.
211	5		Prepare a report on the use of alternative materials for a standard industrial product.
212	5		Repair one item in your home that is not in working condition.
213	10		Write a paper on the safety practices used in a local business or industry.
214	10		Design and build a fixture for a production activity.
215	10		Prepare a video program on safety in the technology lab.
216	10		Prepare a written or oral report on the major advantages and disadvantages of products made of recyclable materials.
217	10		Build a model of an antique power system.

218	10		Develop a bill of materials, flow chart, and illustration of a product suitable for manufacturing in the technology lab.
219	10		Complete a product research activity such as the best type of computer disk, USB flash drive, videotape, house paint, adhesive, etc.
220	10		Write a report about a state-of-the-art production technique.
221	10		Visit an industrial plant and make a flow chart of its operation.
222	10		Design and construct a robot (remote-controlled).
223	10		Assist in the development of a film.
224	10		Prepare a written report on the development of electronics and its effect on society.
225	10		Simulate a space shuttle mission.
226	10		Research an aspect of technology and its effect on the environment and report on the findings to a technology education class.
227	10		Compete in a local TSA event.
228	10		Compete in a state TSA event.
229	10		Compete in a national TSA event.
230	10		Assist an elementary teacher in integrating a technology education activity (from manufacturing, construction, communication, and transportation) into a class lesson (i.e., rocketry, conservation activities, etc.).
231	15		Build a model of a modern communications system and explain the model to your class.
232	15		Construct an apparatus that solves a problem using a combination of at least three systems, such as thermal, electronic, fluid, etc.

### SCHOOL AND COMMUNITY SERVICE

Service is a basic element of a democratic society. The school and community service activities of the TSA Achievement Program help students develop positive attitudes and a desire for serving others. Students should select and complete activities totaling a minimum of twenty points.

Code	Points	Completed	Activity
301	5		Participate in a service project.
302	5		Serve on a membership drive team.
303	5		Assist in a technology education open house.
304	5		Assist in decorating the school for a holiday event.
305	5		Plan activities for Teacher Appreciation Week.
306	5		Participate in a patriotic parade.
307	5		Observe legal proceedings at a court session.
308	5		Attend a city or county government meeting.
309	5		Attend a school board meeting.
310	5		Design and make a patriotic display.
311	5		Attend a student council meeting.
312	5		Meet with the chapter advisory committee at one of its regular meetings.
313	5		Attend a state legislative session, hearing, or committee hearing.
314	5		Write to a state or national member of congress on a current legislative issue.
315	5		Bring and introduce a member of a civic club to a local TSA chapter meeting as your guest.

316	10		Assist the TSA chapter advisor as a lab assistant.
317	10		Visit another TSA chapter and assist in organizing a joint service project.
318	10		Help organize and conduct activities at school for National Science and Technology Week, Career and Technical Education Week, or National Education Week.
319	10		Make holiday toys for charity.
320	10		Plan and direct a school service project.
321	10		Plan and direct a chapter service project.
322	10		Report to a technology education class or to another class on the qualities of a leader. Use TSA materials.
323	10		Attend at least two civic club meetings and report to the chapter advisor on what civic clubs are doing in the community.
324	10		Give a report on TSA to a civic group or trade association (one that is not familiar with TSA) in the local area.
325	10		Assist a technology teacher with tutoring in lower level classes.
326	10		Assist in the installation of another chapter's officers.
327	15		Assist in organizing another chapter.
328	15		Plan and direct a community, state, or national service project.

### CAREER AND PERSONAL PLANNING

TSA students share many common goals, objectives, and interests. They all should learn about their roles in a technology-oriented society. The career and personal planning area of the TSA Achievement Program provides activities that enable students to make wise personal decisions in selecting and preparing for a career. Students should elect and complete activities totaling a minimum of twenty points.

Code	Points	Completed	Activity
401	5		Construct a poster size collage of one of the following occupation areas: construction, design and engineering, communication, transportation, environmental systems, or manufacturing.
402	5		Discuss with family members how and why they made their occupational choices. Summarize responses in a short written report.
403	5		Using the newspaper, clip out five want ads for jobs that appeal to you and write sample letters applying for the positions.
404	5		Identify five strong personality traits that you have, and in a short written report tell how these traits might help you in a particular occupation.
405	10		Ask a minimum of four adults (not family members) about their work and record their responses.
406	10		Research and report on a minimum of four technology-based occupations.
407	10		Make a flow chart outlining your career plans.
408	10		Prepare a written report on the opportunities, working conditions, entrance requirements, etc. of a technology-related occupation of your choice.
409	10		Give an oral report to the class on the opportunities for employment in one of the technology education systems of communications,

			construction, transportation, manufacturing, design and engineering, or environmental systems.
410	10		Obtain and complete a job application from a local business or technology-oriented firm.
411	10		Prepare a written or oral report on where to look for job openings, how to apply, and how to follow-up on job prospects.
412	10		Assist in arranging a class or chapter field trip to a nearby business or technology-oriented firm.
413	10		Assist in arranging a class field trip to a nearby university, community college, career and technical school, apprenticeship program, or other technical skills training program.
414	10		Assist in arranging for a guest speaker from a business or technology-oriented firm.
415	10		Research and report to a class or chapter on the major economic elements of the local community or state.
416	10		Write an article for the local newspaper, school paper, etc. on the benefits of technology education—as they relate to 21st century skills requirements.

### TSA ACTIVITY RESUME

**All documentation is completed online through a Google Document/Form.** Your application must be verified.

---SAMPLE---

CHECK ONE:     Bronze Award     Silver Award     Gold Award

Name: \_\_\_\_\_

Advisor's name: \_\_\_\_\_

School name: \_\_\_\_\_

School address: \_\_\_\_\_

City/State/Zip: \_\_\_\_\_

Total Points: \_\_\_\_\_

\_\_\_\_\_ Date

\_\_\_\_\_ Date

\_\_\_\_\_ Date



## TSA TECHNOLOGY HONOR SOCIETY

### PREFACE

The TSA Technology Honor Society recognizes TSA members who excel in academics, leadership, and service to their school and community. The TSA Technology Honor Society is

- an opportunity for student members to be recognized for their efforts; and
- designed to recognize TSA members who exemplify the high ideals of academics.

### INTRODUCTION

The TSA Technology Honor Society recognizes students for their efforts in academic studies, in leadership, and in service to their school and community.

The goals of the Technology Honor Society are

- *to motivate* TSA members to work to improve and maintain high academic marks;
- *to promote* the undertaking of leadership roles in school and community organizations;
- *to promote* participation in service activities that benefit a school or community; and
- *to recognize* student concern for chapter, school, and community.

### RECOMMENDED SELECTION PROCEDURE

There are two levels of the TSA Technology Honor Society – middle school and high school. Middle or junior high school TSA members may be selected in their 6th, 7th, 8th or 9th grade year, and high school TSA members may be selected in their 9th, 10th, 11th or 12th year; the selection procedure and requirements are the same for both levels.

The chapter advisor, with assistance from other selected faculty members, reviews the academic records of TSA members in the chapter. Students who meet the academic requirements are notified that they are eligible for the TSA Technology Honor Society.

These students, if they wish to apply, must complete the TSA Technology Honor Society resume sheet to document the leadership and service activities they feel are important for Honor Society consideration. They also must submit TSA Technology Honor Society recommendation forms from the TSA chapter advisor.

**All documentation is completed online through an online Google Form, which can be found [here](#). All applications are due one week before the state conference.**

Students inducted into the Technology Honor Society at the state level automatically become members of the national TSA Technology Honor Society.

Students who are members of the Technology Honor Society at the middle school level do not automatically become members at the high school level. Students must reapply at the high school level.

It is not necessary to have been a TSA member at the middle school level in order to be admitted at the high school level.

Chapter advisors and state advisors maintain records of all student resume sheets and a list of names of nominated members. State advisors submit the names of students inducted into the TSA Technology Honor Society, and their inductee fees, to national TSA; resumes and recommendation forms are not submitted to national TSA. **Illinois TSA would pay each national applicant fee; there is no fee for Illinois TSA applicants.**

## REQUIREMENTS

For a student member of TSA to be inducted into the TSA Technology Honor Society, s/he must first meet a set of specified standards or requirements. These standards cover three areas: academics, leadership, and service. (Note: items used for the middle school level application may not be used again for the high school level application.) The requirements are as follows:

- **Academics**
  - Maintain at least a 3.0 grade point average (GPA) based on a 4.0 grade point scale, or equivalent.
  - Maintain a 3.0 grade point average (GPA) based on a 4.0 grade point scale or equivalent in technology education classes, if currently enrolled in such classes.
- **Leadership**
  - Hold at least one chapter, state, or national office, sufficiently fulfilling its duties for one full school year.
  - Hold an office in an organization other than TSA.
  - Attend at least one state (attendance at national conference is not required, but suggested).
  - Place within the top three in a state or national TSA competitive event.
  - Be an active member of TSA in a currently affiliated chapter for at least one semester.
- **Service**
  - Participate in a service project that benefits the school.
  - Participate in a service project that benefits the community.
  - Serve on a chapter, state, or national committee.
  - Give a presentation on TSA to an organization outside one's chapter (i.e., PTA school faculty, board of education, etc.).



**TSA TECHNOLOGY HONOR SOCIETY**  
**SAMPLE RESUME**

Candidate's name \_\_\_\_\_ Grade \_\_\_\_\_

School \_\_\_\_\_ Chapter Level \_\_\_\_\_

School address \_\_\_\_\_

City/state/zip \_\_\_\_\_

*Use additional paper, as necessary.*

**ACADEMICS**

Overall grade point average for the semester \_\_\_\_\_

Technology education class overall grade point average \_\_\_\_\_

**LEADERSHIP**

1. What local, state and/or national office(s) have you held in TSA? (provide the office and the year in which you held the office)

\_\_\_\_\_  
\_\_\_\_\_  
\_\_\_\_\_

2. What offices have you held in other organization? (provide the office and the year in which you held the office)

\_\_\_\_\_  
\_\_\_\_\_  
\_\_\_\_\_

3. What TSA conferences (regional, state, and national) have you attended (provide conference location and the year of the conference)

\_\_\_\_\_  
\_\_\_\_\_  
\_\_\_\_\_

4. List the awards you have earned for TSA competitive events. (provide the year, your ranking and the competition)

\_\_\_\_\_  
\_\_\_\_\_  
\_\_\_\_\_

5. Have you been a TSA member at the local, state, and national level for at least one full school year?  
yes \_\_\_\_\_ no \_\_\_\_\_

6. Have you been an active member of TSA in a currently affiliated chapter for at least one semester?  
yes \_\_\_\_\_ no \_\_\_\_\_

**SERVICE**

7. Which service projects have you participated in that have benefitted your school? Community? Briefly describe each.

\_\_\_\_\_  
\_\_\_\_\_  
\_\_\_\_\_  
\_\_\_\_\_

8. List the chapter, state or national committees that you have served on while in TSA.

\_\_\_\_\_  
\_\_\_\_\_  
\_\_\_\_\_  
\_\_\_\_\_

9. Briefly describe a presentation on TSA that you made to a group other than your chapter.

\_\_\_\_\_  
\_\_\_\_\_  
\_\_\_\_\_  
\_\_\_\_\_

We certify the candidate has completed all the requirements, and we hold all to be true and accurate.

\_\_\_\_\_  
Student Date Chapter Advisor Date

\_\_\_\_\_  
State President Date School Administrator Date

\_\_\_\_\_  
State Advisor Date